

## Production Process 2

Q.P CODE: 58455

Sem 4/Mechanical/ Choice based/ Nov-18

**Q.1]a] classify various additive manufacturing processes? [5]**

**Ans :** It involves manufacturing of 3-dimensional objects from computer model by joining material layer by layer under computer controlled 3D printer.

The material that can be used in this process has no limitation, one can use metal, plastic, concrete or also in future human tissues, it is a 3D printing technique which is also referred as Rapid Prototyping (RP).

It uses additive process and there is no need to remove the material from the workpiece as it is required in traditional or conventional machining.

Nowadays, because of various advantages of AM process, it is widely used in following industries.

1. Automobile industry
2. Aerospace industry
3. Biomedical industry

**Q.1]b] classify various non traditional machining process? [5]**

**Ans: The non-traditional machining process can be classified into various groups on the following basis.**

1. **Types of energy required :** mechanical, chemical, electrochemical and thermoelectric.
2. **Mechanism involved in material removal :** abrasion erosion, ionic dissolution, vaporization, fusion etc. or a combination of these.
3. **Source of immediate energy required for the process:** ultrasonic vibration, hydrostatic pressure, high electric current density, high voltage and amplified light.
4. **Medium of transfer of energy :** abrasive particles, electrolyte, electrons, hot gases, radiation etc.

**Q.1]c] specification of grinding wheel? [5]**

**Ans:**

1. **Hardness :** hardness give the abrasive the ability to penetrate and scratch the material on which it is working.  
Harder the material compared to the material cut, the more efficient it will work.
2. **Toughness :** toughness of the abrasives is required to withstand shock. aluminium oxide being tougher can be used for taking deeper cuts and for machining rough surfaces.

**OUR CENTERS :**

**KALYAN | DOMBIVLI | THANE | NERUL | DADAR**

**Contact - 9136008228**

Toughness is a measure of the resistance to fracture. Tougher the material less likely it is to fracture.

3. **Resistance to attrition** : dulling of the grains occurs due to the attrition. Kristen Stewart reaction is required for controlling the dulling of the grains. Attrition is a function of the hardness of the material and chemical affinity to the material being cut.

**Q.1]d]describe how a compound and combination die differ from each other [5]**

**Ans: compound dies**

1. A combined pair of two points and die sets at one station
2. two or more operations performed on the same stations one after the other
3. Functions performed are of similar kind such as blanking and piercing
4. The job is complicated one station after stock is feed to the die.
5. Job complete at the station

**Combination dies**

1. A combined pair of two points and assets at one station.
2. two operations performed on the same station one after the other in one stroke
3. functions performed are different types such as shearing and drawing for blanking and forming
4. The job in completed at one station after the stock is feed to the die.
5. Job completed at the station.

**Q.1]e] prove that in metal cutting chip low velocity coefficient = cutting velocity × chip thickness coefficient [5]**

**Ans: in the above eq i.e.  $v_c$ ,  $v_f$  and  $v_s$  generally  $v_c$  is always known. Hence for calculating other two velocities following method is used**

$$\frac{v_f}{\sin\phi} = \frac{v_c}{\sin(90 - \phi + \alpha)} = \frac{v_s}{\sin(90 - \alpha)}$$

$$\frac{v_f}{\sin\phi} = \frac{v_c}{\cos(\phi - \alpha)} = \frac{v_s}{\cos\alpha}$$

$$v_f = \frac{v_c \sin\phi}{\cos(\phi - \alpha)}$$

$$v_s = \frac{v_c \cos\alpha}{\cos(\phi - \alpha)}$$

As in orthogonal cutting system,

Chip velocity coefficient = cutting velocity × flow velocity

**OUR CENTERS :**

**KALYAN | DOMBIVLI | THANE | NERUL | DADAR**

**Contact - 9136008228**

$$(t_1 \cdot w) \times v_c = (t_2 \cdot w) \times v_f$$

$$v_c \cdot t_1 = v_f \cdot t_2$$

$$v_f = \frac{v_c \cdot t_1}{t_2}$$

$$v_f = v_c \cdot r$$

**Q.2[a] what is EDM write about its application advantages and limitations. Also state that functions and requirements of dielectric fluid. [10]**

**Ans: The process**

Electrical discharge machining also called as spark erosion spark erosion machining is it thermal metal removal process based on a control erosion of the workpiece material by repetitive electric sparks between the workpiece and performed tool.

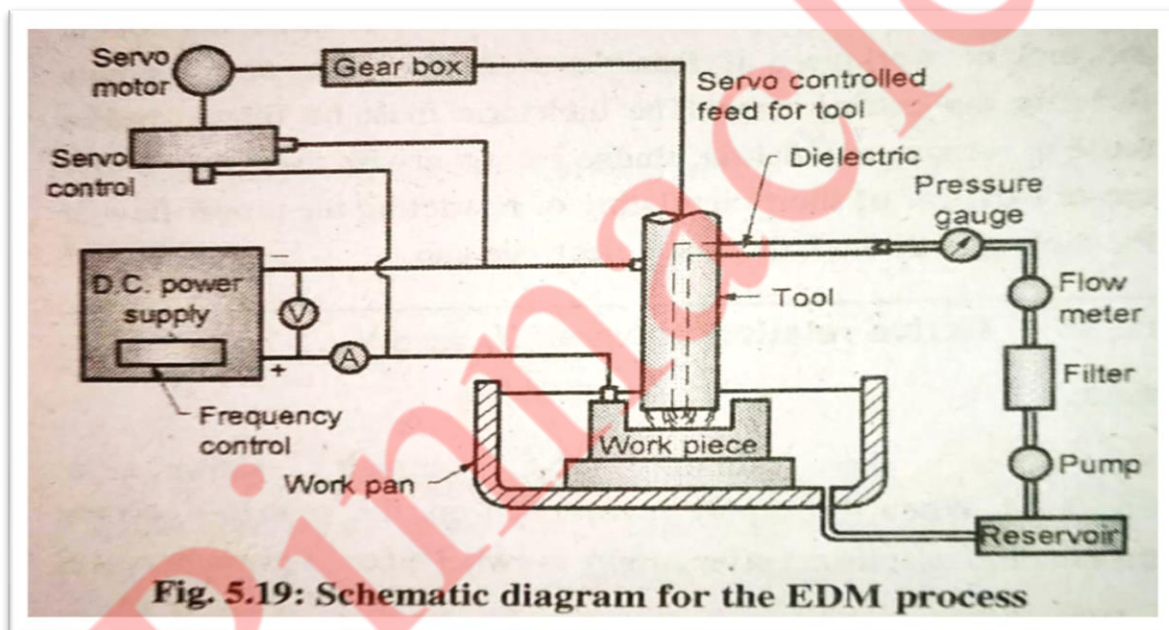

**Fig**

As shown in figure the tool and workpiece are maintained a constant distance a part and a dielectric fluid is circulated through the gap to provide controlled amount of electric resistance between the two.

- A dielectric is a fluid that is non conductor of electricity example an insulator in which an electric field does not give rise to flow of charge.
- A voltage in excess of The breakdown voltage of the gap is required to initiate a discharge across the gap. When such a DC pulse is delivered to the electrodes a breakdown of the electric field occurs due to ionization of the dielectric fluid at the point where the distance between the surface irregularities on the tool and the workpiece is the shortest.

**OUR CENTERS :**

**KALYAN | DOMBIVLI | THANE | NERUL | DADAR**

**Contact - 9136008228**

- This leads to the formation of a conducting electric path and a spark occurs.
- A small amount of material from the surface of the workpiece and tool is melted and vaporized by this temperature. Switching off the current supply at the end of the pulse causes a sudden inrush relatively cool dielectric fluid which exclusively express the metal and third forms a small crater in both the workpiece and tool surface.
- The debris generated by the spark erosion are removed by the circulating dielectric fluid while the sparking action ships to another place where the gap is the shortest.
- In actual machining operation, the metal erosion process described above is repeated at hundreds of thousands of Sparks across the tool face. As the tool and the work surfaces eroded the tool is advanced gradually into the workplace by server feed system which maintains the gab at a constant value between 0.01 to 0.12 to mm.
- The final shape of the workpiece reproduced by EDM is a reverse image of the tool

### **Advantages**

- can be used on even hard materials like tungsten carbide and alloys.
- Good surface finish.
- Tool Materials need to be harder than work material so material that can be easily shaped can be selected for tool.
- Can machine even complicated shapes.

### **Disadvantages**

- Cannot be used for electrically non conducting materials.
- In some cases the surface produce is found to have microcracks.
- The degree of accuracy can be affected by tool wear
- Normally applicable only for small jobs.

### **Functions and requirements of dielectric fluid**

The dielectric fluid generally used are petroleum, based hydrocarbon fluids liquid, paraffin, white spirit, transformer oil, kerosene, mineral oil or mixture of these.

Circulation of the dielectric fluid of flushing as it is called can be done through a hole in the tool or workpiece if visible from the side or by simply flooding the cutting zone.

The dielectric must be filtered before use to remove any debris, sludge's, etc. at this day 20 may create a danger of short circuiting or restricting the proper flow of dielectric through the small electrode gap.

### **Dielectric selected is expected to satisfy the following requirements:**

1. Remain perfectly non-conductive until the required breakdown voltage is reached.
2. At The breakdown voltage it should breakdown electrically in the shortest possible time.
3. Should have high dielectric strength.

**OUR CENTERS :**

**KALYAN | DOMBIVLI | THANE | NERUL | DADAR**

**Contact - 9136008228**

4. Deionized The spark gap rapidly after the spark has occurred.
5. Provide the effective cooling rate.
6. be capable of carrying the debris in suspensions away from the cutting zone.

**Q.2]b) state the different sources of heat in metal cutting**

**[10]**

**Ans :**

1. In machining operation, energy supplied is converted into heat energy in heat zone.
2. heat generated =  $W.D=fc.vc$   **$W.D=fc.vc$**
3. fig. shows the heat generated zones during machining.
  - 1) primary heat zone.
  - 2) secondary heat zone.
  - 3) tertiary heat zone.

1) primary heat zone:

1. During metal cutting operation, plastic deformation of metal takes place on the shear plane, due to which heat is generated.
2. Around 60 to 65 % energy is converted into heat energy. But of which maximum amount of energy is carried away by chip and small amount of energy is transferred to work piece.

2) secondary heat zone:

1. tool chip interface, energy supplied is converted into heat energy due to friction at chip and tool contact.
2. Around 30 to 35 % of energy supplied is converted to heat energy.  
Out of heat generated maximum amount of energy carried away by chip and small amount by work piece.

3) Tertiary heat zone:

1. Energy supplied is converted into heat energy due to presence of friction between tool and work piece entrance.
2. 5 to 10 % of energy supplied is converted into heat energy. here, maximum amount of energy is transfer to the work piece and small to the tool.
3. Neglecting heat carried away to the atmosphere. Therefore considering total heat generated during machining is carried away by chip, work piece and tool.

**1. Around shear plane :**

- During machining. plastic deformation of metal occurs on the shear plane, due to which heat is generated. This heat is carried away by the chip because of which its temperature is raised.
- The remaining heat is retained by the workpiece and is known as primary deformation zone.
- Heat generated at the shear plane is due to internal friction and it is about 65 75 % of the total heat generated.

**OUR CENTERS :**

**KALYAN | DOMBIVLI | THANE | NERUL | DADAR**

**Contact - 9136008228**

**2. Tool-chip Interface:**

- When the chip flow upwards along the tool face, friction occurs between their surfaces, hence heat is generated.
- This heat is carried by the chip which increases the temperature of the chip and remaining is transferred to the tool and coolant. This area is called as **secondary deformation zone**. The heat generated is 15 25 % of the total heat generated.

**3. Tool-work piece interface :**

- Another source of heat generation due to friction is, tool flank which rubs against the work surface. Heat generated is 10% of the total that heat generated.
- This heat is carried by the tool, work piece and coolant. When the tool is not sufficiently sharp, then heat generation in this region is more.
- The knowledge of cutting temperature is important because it affects the wear of cutting tool, can induce thermal damage to machined surface and causes errors in the machined surface.
- There are various methods of cutting temperature measurement as follows:
  1. Tool work thermocouple
  2. Radiation pyrometer
  3. Embedded thermocouple
  4. Calorimetric method

**Q.3]a] explain various sheet metal production process with neat sketches [10]**

**Ans :** Press operations may be grouped into two categories

1. Cutting operations
2. Forming operations.
  - In cutting operations the sheet metal is stressed beyond its ultimate strength whereas in forming operations the stresses are below the ultimate strength of the metal.
  - Metal cutting operations
  - In sheet metal operations the metal is sheared hence also called as shearing operations
  - In this operation the metal sheet is stretched beyond its ultimate strength They include following operations
    - i. Blanking
    - ii. Punching
    - iii. Notching
    - iv. Perforating
    - v. Slitting
    - vi. Lancing
    - vii. Shaving
    - viii. Shearing
    - ix. Nibbling

**OUR CENTERS :**

**KALYAN | DOMBIVLI | THANE | NERUL | DADAR**

**Contact - 9136008228**

## Blanking

- Blanking is a cutting operation of a flat metal sheet and the article punched out is known as blank
- Blank is the required product of the operation and the metal left behind is considered as a waste

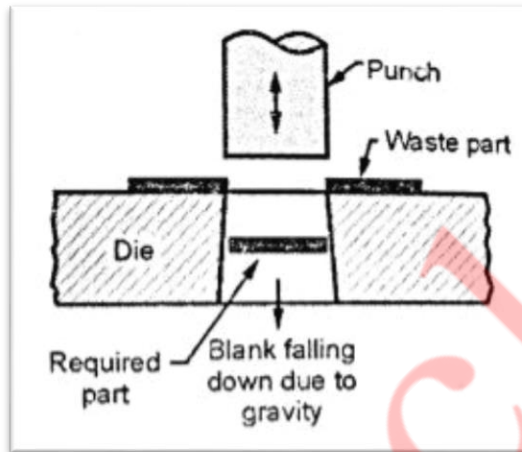

Fig 1

## Punching

- It is the cutting operation with the help of which holes of various shapes are produced in the sheet metal
- It is similar to blanking only the main difference is that, the hole is the required product and the material punched out from the hole is considered as a waste.

**OUR CENTERS :**

**KALYAN | DOMBIVLI | THANE | NERUL | DADAR**

**Contact - 9136008228**

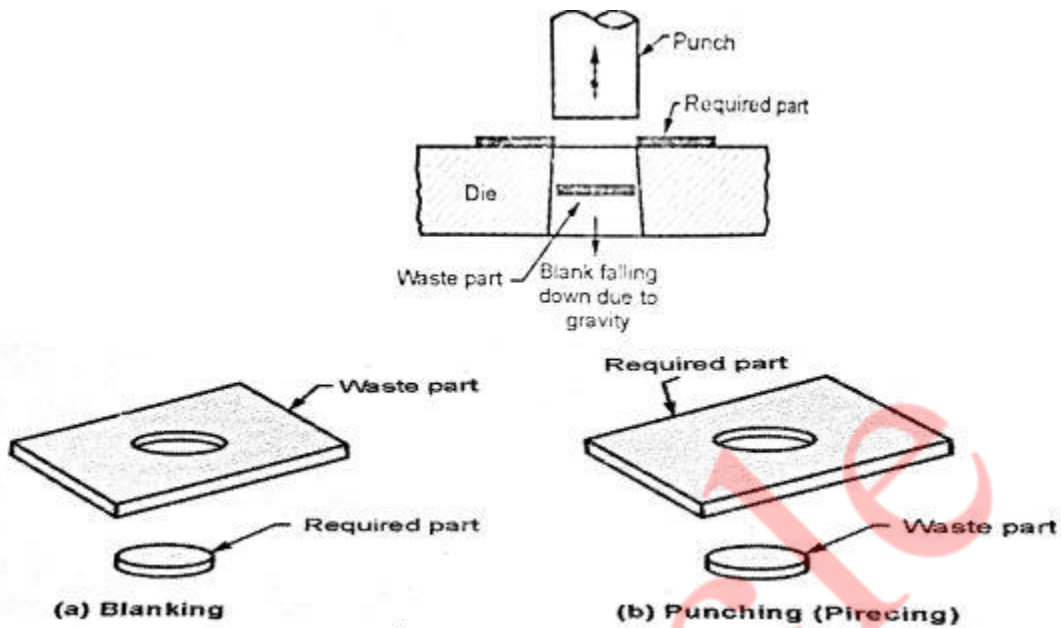

Fig 2

### Notching

- Similar to blanking however the full surface of punch does not cut the metal
- In this operation the metal pieces are cut from the edges of a sheet

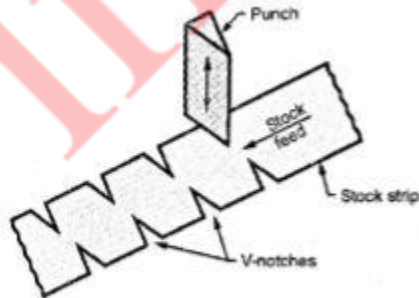

Fig. 2.6 : Notching

Fig 3



**Q.3]b] Define jigs and fixtures describe the following with neat sketches**

**1) locators 2) clamping devices.**

**[10]**

**Ans: Definition of jig**

A jig may be defined as a device, which holds and locates a workpiece as well as guides and controls one or more cutting tools.

**Definition of fixture**

A fixture is defined as a device used for holding and locating a component or workpiece securely in a definite position but it does not guide the cutting tool. **Fig 1**

Based on their shape the locators can be classified as (i) flat (ii) cylindrical (iii) conical and (iv) Vee. They may be fixed or adjustable according to circumstances. Some typical locators are explained further :

**Pads, pins and buttons :**

These locators control the workpiece from flat surfaces or from a profile. A round pin or button is used to support the job firmly and hold it in position.

The main difference between pins and buttons is in length. Buttons are shorter in length than pins and are generally used for vertical location.

Larger sizes of pins are sometimes referred to as Plugs. position shows simple support pad used to position or support the workpiece from a flat surface

If the workpiece is located from more than one face in a given plane adjustment must be provided for the pads and pins at the additional faces. Fig. illustrates a simple adjustable pin or pad. Figs. illustrate use of pins for location from a profile of workpiece.

**OUR CENTERS :**

**KALYAN | DOMBIVLI | THANE | NERUL | DADAR**

**Contact - 9136008228**

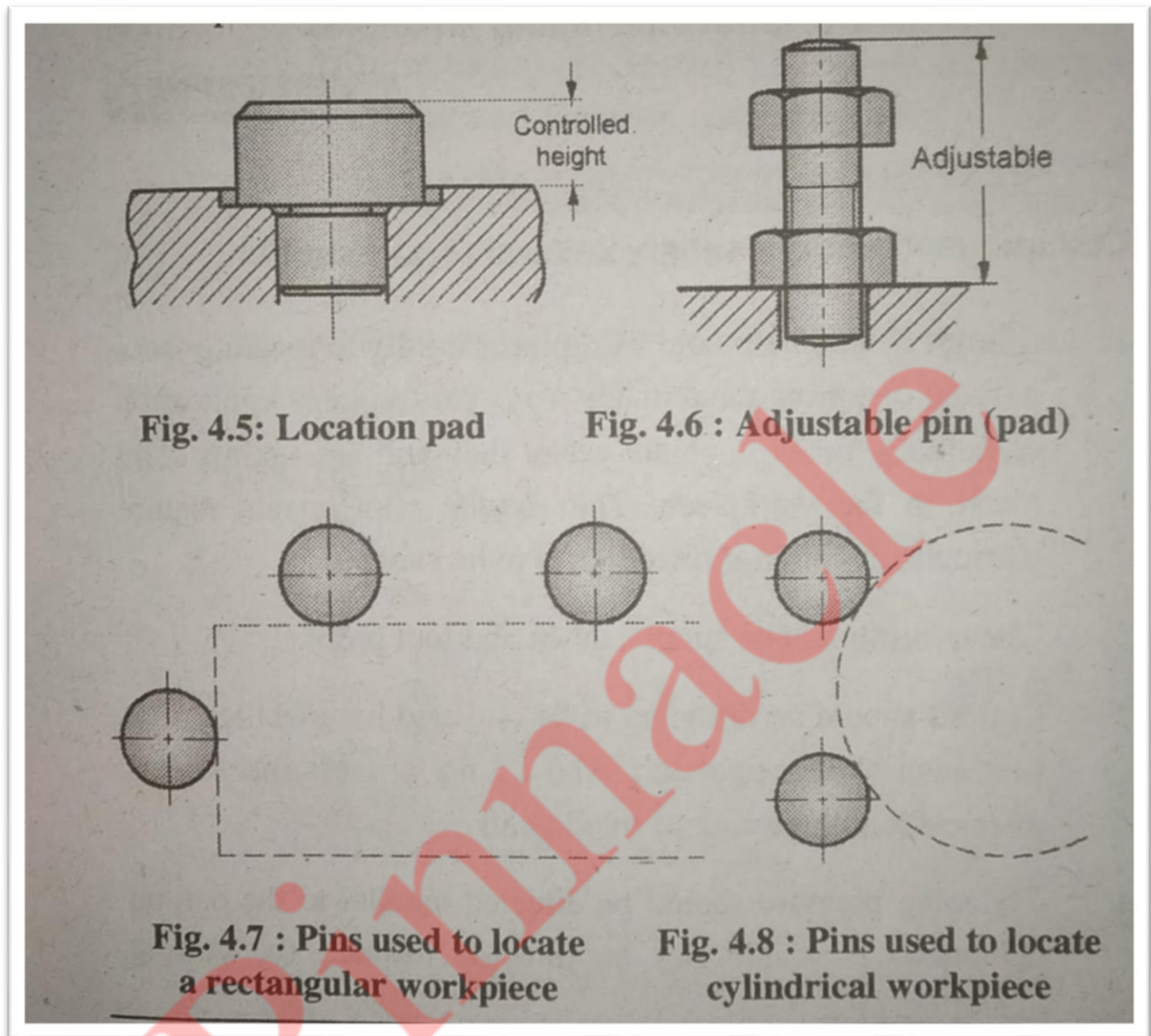

**Fig 1**

**Cylindrical locator :**

Cylindrical post locators locate the workpiece from a cylindrical bore feature. Fig. shows a short cylindrical locator which, with a qualified base, provides five of the six locators of the 3-2-1 location system.

Locators must be accurately positioned relative to the base and kept as short as possible to prevent binding during loading and unloading of the workpiece

Location posts must be given a generous lead to facilitate loading and should sit in a recess in the base so that dirt and chips will not prevent the workpiece from being comically scatted (Fig. 49).

**OUR CENTERS :**

**KALYAN | DOMBIVLI | THANE | NERUL | DADAR**

**Contact - 9136008228**

When a location post is used in conjunction with clamping it must be secured to the base otherwise it may be pulled out by the clamping force.

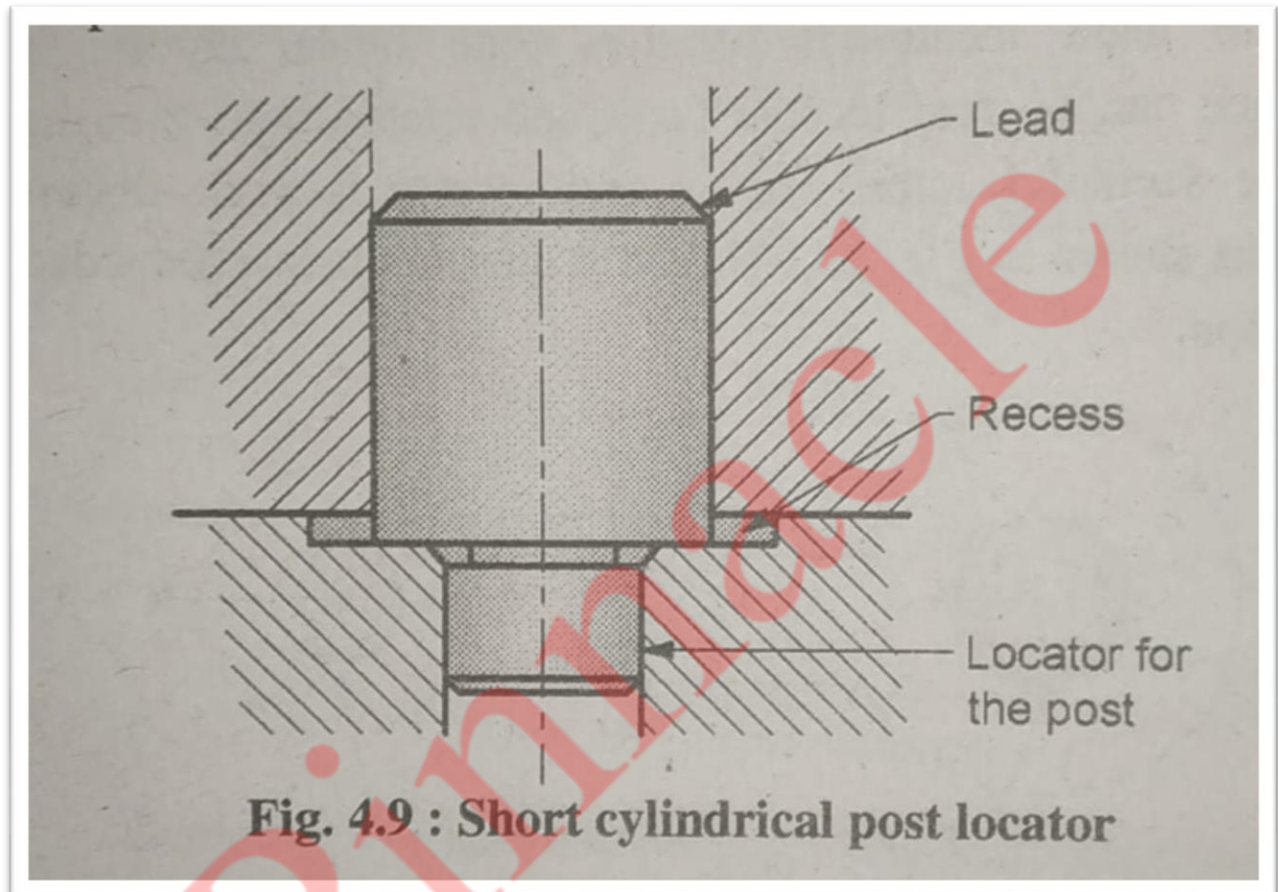

**Fig 2**

**Some of the commonly used clamping devices are discussed below. They can be divided into following groups:**

#### **Screw clamps**

Screw clamps are simple clamps which are generally applied on the side face of the workpiece thus leaving the top face free for machining.

A typical screw clamp is shown in Fig. It carries a floating pad at the end to prevent workpiece displacement and to prevent screw deflection.

**OUR CENTERS :**

**KALYAN | DOMBIVLI | THANE | NERUL | DADAR**

**Contact - 9136008228**

The pad remains stationary on the workpiece while the screw rotates. The floating pad is attached to the screw by a pin, screw or ball. Fig. shows another design of screw clamp.

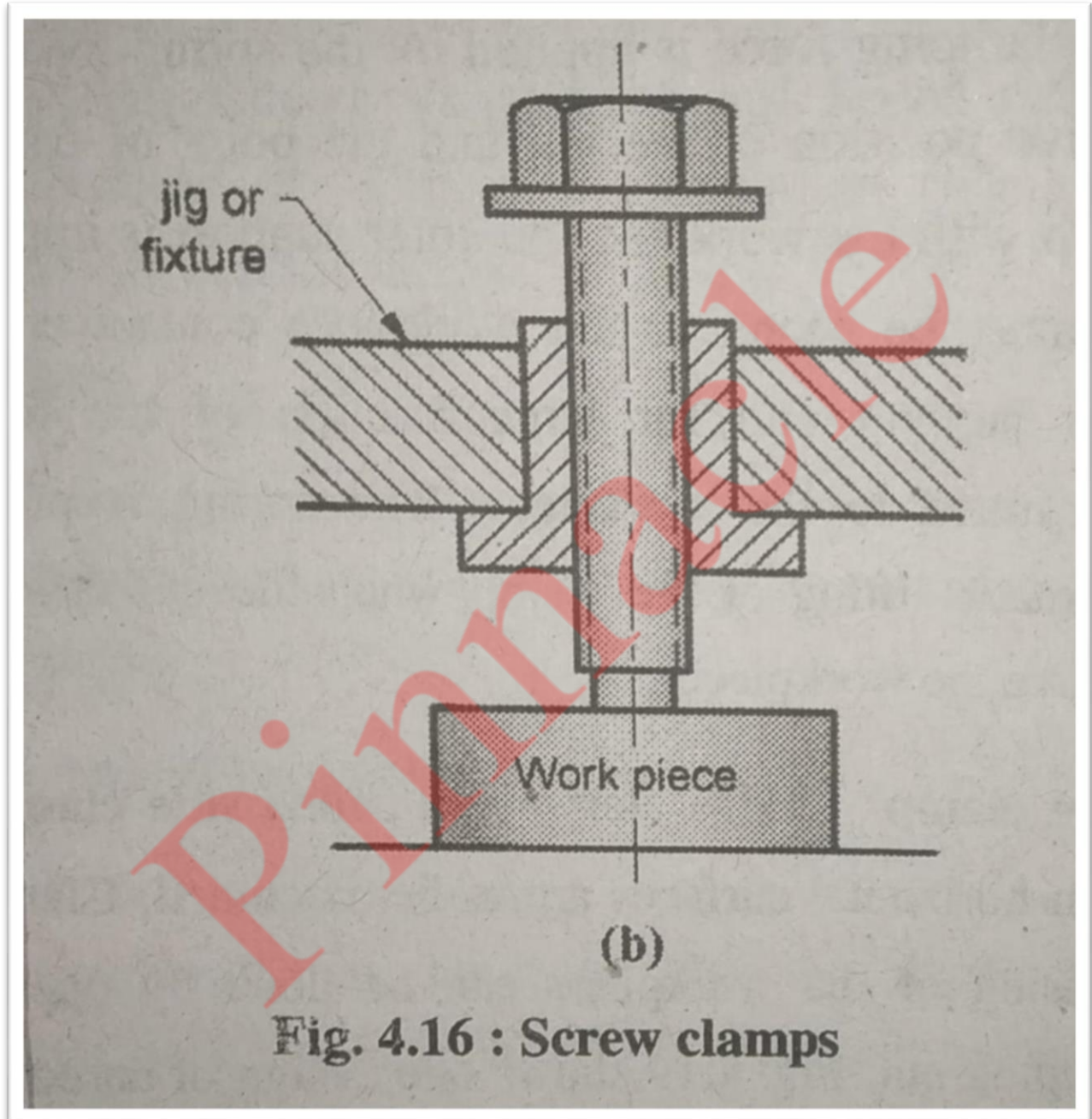

### Hook bolt clamps

A hook bolt clamp shown in Fig. is a very simple device useful for light work where other types of clamps are inconvenient.

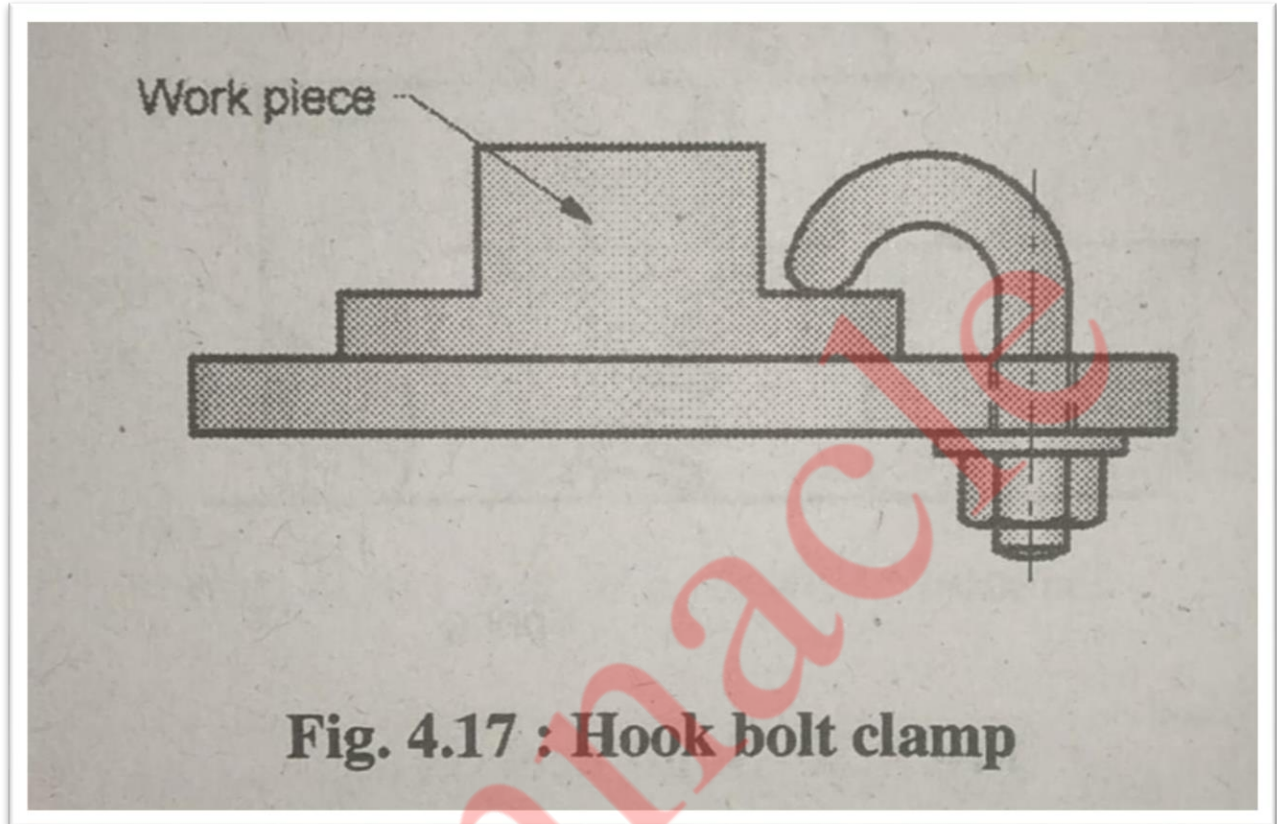

Fig

Q.4[a] washing machine in steel with the tool of [0-10-6-6-8-75-1] ORS ship following observations where made.

- 1) spindle speed 3000 RPM
- 2) work diameter 40 mm
- 3) depth of cut 3.5 mm
- 4) tool feed rate 70 mm/minute
- 5) cut chip thickness 0.55 mm

[10]

Ans : -Metal Cutting

Tool 01066751 As N= 400 rpm ;

D =2.5 mm

**OUR CENTERS :**

**KALYAN | DOMBIVLI | THANE | NERUL | DADAR**

**Contact - 9136008228**

$$f = 80 \text{ mm/min} = 80/400 = 0.2 \text{ mm/rev.} = t$$

$$t_c = 0.40 \text{ mm}$$

To find :  $r, \phi, \epsilon, l_c$

Rake angle  $\alpha = 10^\circ$

$$t = 0.2$$

Chip thickness ratio  $r_c$

$$r_c = \frac{t}{t_c} = \frac{0.2}{0.4} = 0.5$$

$$\tan \alpha = \frac{r_c \cos \alpha}{1 - r_c \sin \alpha} = \frac{0.5 \cos 10}{1 - 0.5 \sin 10}$$
$$= \frac{0.5 \times 0.9848}{1 - 0.5 \times 0.1737} = 0.5392$$

$$\phi = 28.33^\circ$$

Shear strain  $\epsilon$

$$= \frac{\cos \alpha}{\sin \phi \cos(\phi - \alpha)}$$
$$= \frac{0.9848}{0.4745 \times 0.9493} = 2.186$$

Uncut chip length/min

$$= rDN = \pi \times 60 \times 400$$
$$= 75398.2 \text{ mm}$$

Chip length  $l_c$

$$l \times r_c = 75398.2 \times 0.5$$
$$= 37699.1 \text{ mm/min}$$

**OUR CENTERS :**

**KALYAN | DOMBIVLI | THANE | NERUL | DADAR**

**Contact - 9136008228**

**Q.4]b) Explain photo polymerization with respect to principle of operation process advantages and disadvantages. Explain its application in relevance CMET and 3D systems [10]**

**Ans :** Photo polymerization processes make use of liquid, radiation curable resins, or photopolymers as their primary materials.

- Most photopolymers react to radiation in the ultraviolet (UV) range of wavelengths, but some visible light systems are used as well. Upon irradiation, these materials undergo a chemical reaction to become solid.
- This reaction is called photo polymerization, and is typically complex, involving many chemical participants.
- Photopolymers were developed in the late 1960s and soon became widely applied in several commercial areas, most notably the coating and printing industry.
- Many of the glossy coatings on paper and cardboard, for example, are photopolymers. Additionally, photo-curable resins are used in dentistry, such as for sealing the top surfaces of teeth to fill in deep grooves and prevent cavities.
- In these applications, coatings are cured by radiation that blankets the resin without the need for patterning either the material or the radiation. This changed with the introduction of stereo lithography.
- Most **photo polymerization** reactions are chain-growth polymerizations which are initiated by the absorption of visible or ultraviolet light.
- The light may be absorbed either directly by the reactant monomer, or else by a **photosensitizer** which absorbs the light and then transfers energy to the monomer.
- In general, only the initiation step differs from that of the ordinary thermal polymerization of the same monomer; subsequent propagation, termination and chain transfer steps are unchanged

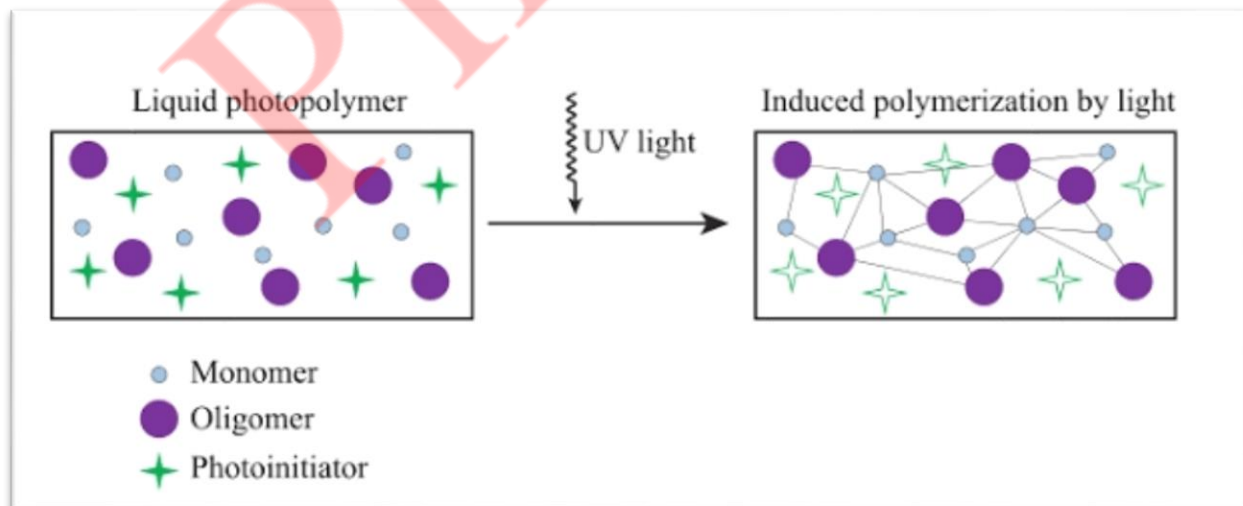

**Fig 1 Photo polymerization**

**OUR CENTERS :**

**KALYAN | DOMBIVLI | THANE | NERUL | DADAR**

**Contact - 9136008228**

### Application of photo polymerization

1. Photo polymerization can be used as a photographic or printing process, because polymerization only occurs in regions which have been exposed to light.
2. Unreacted monomer can be removed from unexposed regions, leaving a relief polymeric image.
3. Several forms of 3D printing including layer by layer stereolithographic and two-photon absorption 3D photo polymerization use photo polymerization.

**Q.5]a] Discuss the geometry and design steps for a brooch tool with the help of diagram. [10]**

**Ans :** The important features of an internal pull type broach are shown in the figure.

1. General considerations in design of various elements of broach discuss below.

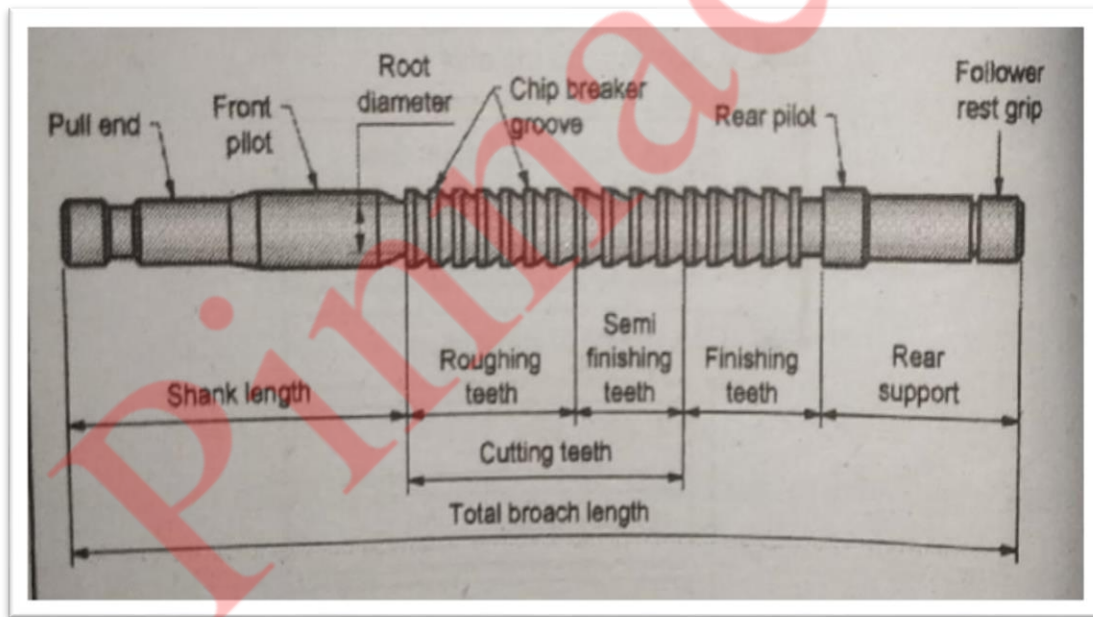

**Fig 1 Internal pull type broach**

- **Root diameter:** The root diameter of the minimum size of the broach is determined by the force required to pull or push the broach. This size occurs at the root of the first tooth or Shank at the pool end. This root diameter of the broach must be capable of which standing the broaching for in tension or in compression and buckling as the case may be
- **Pitch:** The pitch of the teeth is one of the very important design feature of the broach. it determines the length of the broach and the number of teeth simultaneously in contact with the work piece.

**OUR CENTERS :**

**KALYAN | DOMBIVLI | THANE | NERUL | DADAR**

**Contact - 9136008228**



It also decides the construction and the size of the teeth and ability of the broach to hold its alignment during the cutting stroke

- **Chip space:** In any broaching operations it is the grounds to distinguish throughout the chip form is trapped and cannot escape till the tooth leaves a work piece. The space provided between the teeth should therefore large enough to accommodate the chips form without cramping or crowding them. Properly designed chips space will make the chip to curl and roll up while a faulty design or inadequate space will break the chip which may scratch the job and increase the frictional resistance.

Broach Geometry / Elements of a Broach

Fig. shows the details of pull type internal broach for producing a cylindrical hole.

- The broach is gripped at the shank end by the puller. Before the teeth, front pilot enters into the hole to keep proper alignment.
- Broach consists of three sets of cutting teeth. The first set is called as roughing teeth, which does most of the cutting operation.
- The second set is semi finishing teeth, which removes low stock as compared to the first set. The size of the second set is little larger than first set.
- The third set is used for finishing operation hence called as finishing teeth, but the size of finishing teeth does not vary. Finishing teeth removes very small amount of material which is almost negligible.

Fig. shows the details of broach teeth. The principal elements of a common type of broach are as follows:

(1) Pull end :

The end of the pull broach, which contains shank, is the pull end. The broaching machine puller head grip this end of a broach.

(2) Front pilot:

It guides the broach into the hole and keeps it concentric with latter. It helps in starting a straight cut.

(3) Rear pilot :

Its size and shape confirms to those of the finished hole and provides support to the broach after the cutting process is over.

(4) Land :

It is the extreme top part of the tooth and it is normally ground slightly to provide clearance.

**OUR CENTERS :**

**KALYAN | DOMBIVLI | THANE | NERUL | DADAR**

**Contact - 9136008228**

(5) Tooth gullet :

It is also known as chip space. It provides space for the chips to curl and escape. The too small space spoil the hole surface as the chips will rub against it.

(6) Pitch :

The linear distance measured between the cutting edge of one tooth and corresponding point on the next tooth is called pitch. But it is not the same for all the teeth of the broach. It is different for the three sets of teeth i.e. roughing, semifinishing and finishing teeth.

(7) Back off angle:

It is also known as clearance angle and is ground on the land to provide relief. Its value normally varies from  $0.5^\circ$  to  $3^\circ$ , values from  $1.50$  to  $2^\circ$  being very common. For finishing teeth no clearance is provided.

(8) Hook or rake angle:

It is also known as face angle. It is similar to rake angle provided on single point tool. It depends upon the material to be cut and varies from  $3^\circ$  to  $150$ , most common value is in between  $12^\circ$  to  $150$

(9) Hook radius:

It is the radius contained by the bottom of the gullet. It should have a very polished and smooth surface so as to prevent sticking of chips in the gullet.

**Q.5]b] Discuss in detail various factors affecting the tool life two cutting tools are being compared for a machining operation. The to life equations are are carbide tool  $VT^{1.8} = 2000$  and HSS tool  $VT^{0.8} = 135$  very where is the cutting speed in m/min and T is the to life in min. calculate the cutting speed value so that the carbide tool will provide higher to life than HSS tool [10]**

**Ans :**

### **Factors Affecting Tool Life**

(a) Cutting speed :

Cutting speed is the major factor for affecting the tool life,

It varies inversely with the tool life which leads to the generation of a parabolic curve as shown in Fig.

The relation between the tool life and cutting speed is invented by F.W. Taylor, hence sometimes that equation is called as Taylor's tool life equation.

The relation is,

$$VT'' = C$$

**(b) Feed and Depth of cut:**

Feed and Depth of cut are important parameters which affect the tool life appreciably.

They are also inversely proportional to the tool life.

**(c) Tool geometry:**

Geometrical parameters (tool angles) of a cutting tool affect the tool performance and tool life.

If the rake angle is increased in positive direction, then the cutting force and heat generation are reduced which increases the tool life.

Whereas, if it is too large, then it reduces mechanical strength of the tool and hence the tool life.

Hence, the rake angle should be between  $-5^\circ$  to  $+10^\circ$  where, negative sign indicates negative rake angle.

Relief or clearance angles are used to prevent the rubbing of the tool flank against work surface. If it is too large, then weakening of the tool occurs and hence reduction in the tool life. Generally, it varies from 5 to 80.

**(d) Tool material :**

Tool material which can withstand maximum cutting temperature without losing its mechanical properties and geometry will ensure maximum tool life.

Hence, higher the mechanical properties (mostly, hardness and toughness) in the tool materials longer be the tool life. (0) Work materials:

Higher the hardness of the work materials greater will be the tool wear and hence shorter tool life.

At high temperature, metals have tendency to stick to the tool face which results in more friction, high amount of wear on the tool and hence shorter tool life.

**Solution**

For carbide  $VT^{1.8} = 2000$

$$T_C = \left( \frac{2000}{V^{1.8}} \right)^{1/1.8} = \frac{68.21}{V^{0.555}}$$

For HSS  $VP^{0.8} = 135$

$$T_{HSS} = \frac{460.16}{V^{1.25}}$$

For equal tool life

$$\frac{68.21}{V^{0.555}} = \frac{460.16}{V^{1.25}}$$

**OUR CENTERS :**

**KALYAN | DOMBIVLI | THANE | NERUL | DADAR**

**Contact - 9136008228**

$$v = 28.32 \text{ m}$$

At  $v = 30 \text{ m/min}$

$$t_c = \frac{68.21}{30^{0.555}} = 10.32 \text{ min}$$

$$t_{HSS} = \frac{460.16}{v^{1.25}} = 6.55 \text{ min}$$

**Q.6 write short note on. [20]**

**a) Concept and importance of additive manufacturing [5]**

**Ans:** Additive Manufacturing (AM) is a technology which is rapidly developing and being integrated into manufacturing and our day-to-day lives.

In the commercial world it has been labeled by different names, such as Three-Dimensional (3D) Printing, Rapid Prototyping (RP), Layered Manufacturing (LM) and Solid Freeform Fabrication (SFF).

Basically, AM is an approach where 3D designs can be built directly from a Computer-Aided Design (CAD) file without any specific tools or dies.

In this freeform layer-wise fabrication, multiple layers are built in the X-Y direction one on top of the other generating the Z direction or third dimension.

Once the part or component is built, it can be used for touch and feel for concept models, tested for functional prototypes or used in actual practice.

AM is much more than a process that can be used to make personalized novel items or prototypes.

AM will cause the manufacturing process of many things to change as well as cause a new style of customer-to-manufacturer interaction.

Integration of 3D printing will make it so people can contribute to the design process from almost any location and will break the barriers of localized engineering and take it to a global scale.

By using AM, designs can be made and tested from almost any location with very little lead time.

This technique will enable manufacture of products from anywhere in the world in a timely

**b) laser beam machining [5]**

**Ans :** Laser Beam Machining (LBM)

Laser is the term applied for phenomenon of amplification of light by stimulated radiation emission.

**Construction**

Fig. shows the setup of Laser Beam Machining which consists of a stimulating light source (Xenon flash lamp) and a laser rod.

Laser rod or laser tube consists of a pair of mirrors, which are placed at each end of a tube.

Setup also consists of a flash tube /lamp (energy source), laser, power source, focussing source (lens) and cooling system.

The whole setup is fitted inside an enclosure which has highly reflective surface inside it.

The laser used in the process may be solid, liquid or gaseous type. The solid type carries reflective coatings at their ends and gaseous type produces continuous

laser beams and is suitable for welding and cutting operations. Most commonly used laser is Ruby.

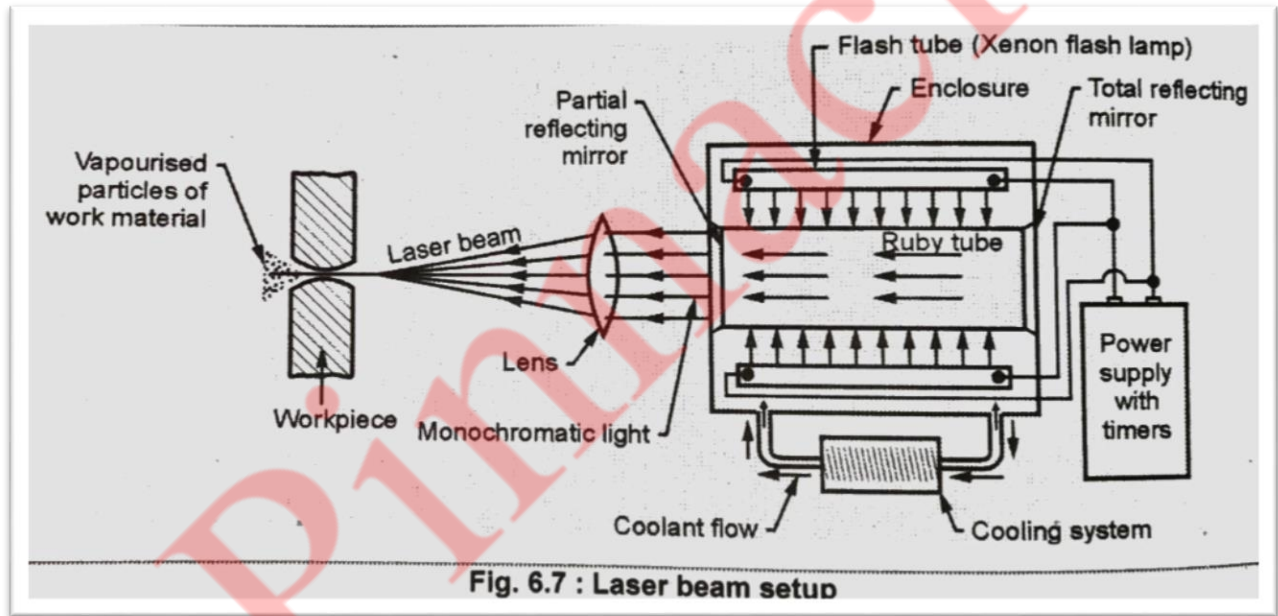

Fig 1

### Working

In operation, the optical energy (light) radiated from the flash lamp is focused on the laser rod (tube), from where it is reflected with the help of mirrors and accelerated in its path.

The reflected light is emitted in the form of a slightly divergent beam.

A lens is placed in the path of this beam of light which converges and focuses the light beam on the component to be machined (workpiece).

This impact of laser beam on the component melts the work material and due to this it vaporizes. Hence it is also called as thermal cutting process.

c) lathe tool dynamometer.

[5]

**Ans: Strain Gauge Type Dynamometer**

Strain gauge type dynamometer is also called a turning dynamometer.

This type mechanical methods for measuring strains are not very of gauges are widely used because reliable.

It is an electro-mechanical technique and the dynamometer used in the process can be termed as electro-mechanical dynamometer.

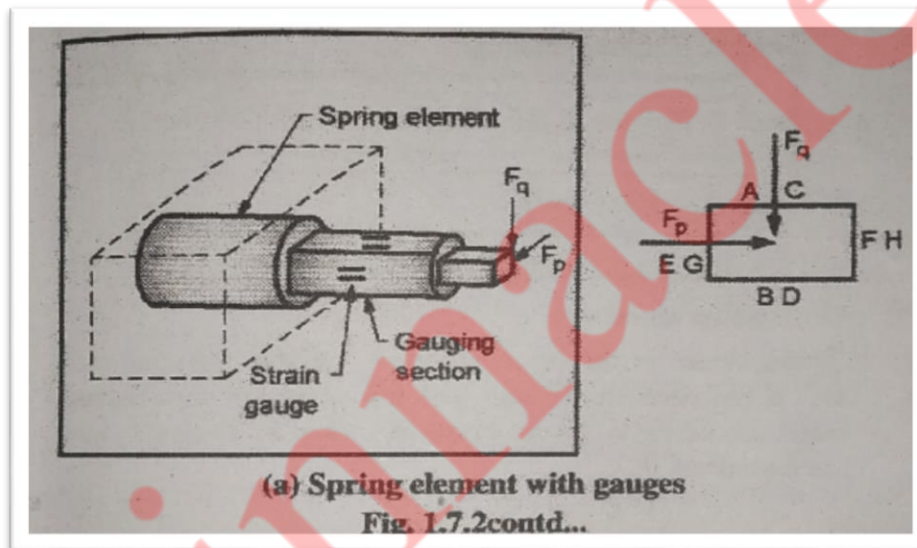

**Fig 1**

Wheatstone bridge circuit is commonly used in conjunction with electrical strain gauges.

The forces being measured by this method are the cutting force ( $F_c$ ) and axial or thrust force ( $F_t$ ).

It is a cantilever type design, where substantial length of the dynamometer along with the tool projects outwards.

The basic principle involved in this technique is that, the electric resistance of a wire changes when it is stretched.

A square sectioned machined surface is formed on the body, carrying flat surfaces, for sticking strain gauges over there. Refer Fig. The strain gauges are cemented on to the four flat surfaces with the help of adhesives.

**OUR CENTERS :**

**KALYAN | DOMBIVLI | THANE | NERUL | DADAR**

**Contact - 9136008228**

The given set-up carries two sets of strain gauges i.e. one set (pair of gauges) on the top and bottom surface and the second set on the two vertical surfaces on the two sides as shown in enlarged view (X-X).

These two sets are connected one each to two separate Wheatstone bridge circuits.

During experiment, the different pairs of gauges are subjected to tension and compression, as per the force applied.

In the given case, because of force  $F$  the top surface is subjected to tension (gauges A and B) and bottom surface is subjected to compression (gauges C and D).

Similarly, because of force  $F$  strain gauges P and Q are subjected to tension and R and S subjected to compression. The arrangement of gauges (A, B, C, D) of the first set in Wheatstone bridge circuit is shown in Fig.

In the similar way the gauges of second set (P, Q, R, S) are arranged in another Wheatstone bridge circuits

Now, the resistance of the strain gauges subjected to tension increases and resistance of strain gauges subjected to compression decreases due to change in their lengths.

These changes are measured by the Wheatstone bridge and with the help of standard formulae strains, stresses and forces responsible for causing these changes are measured.

**d) Diamond pin locator**

[5]

**Ans:** Diamond Pin Locators (Angular Locators)

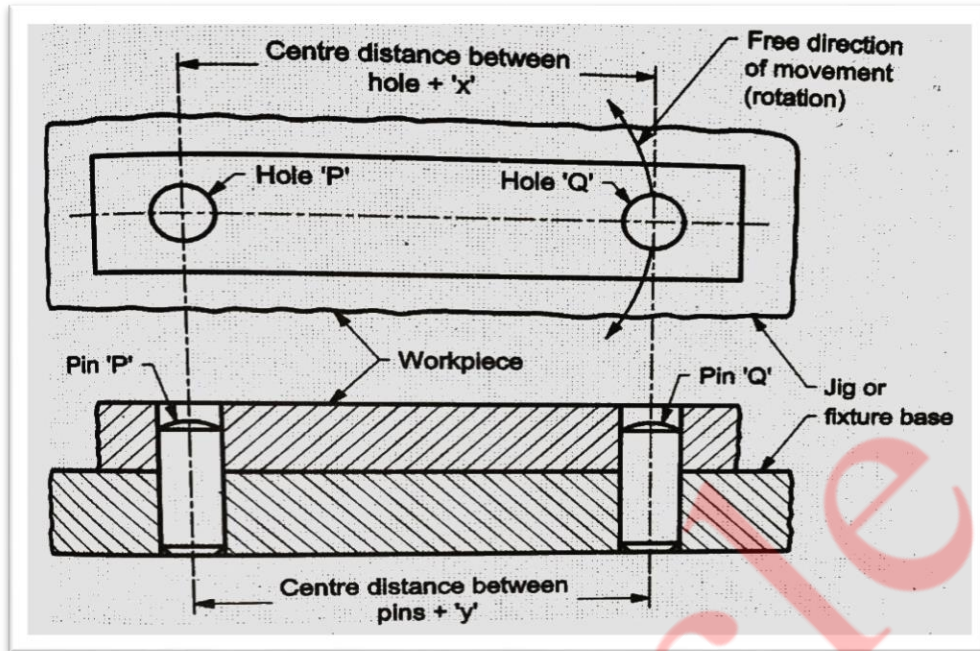

Fig 1

Components which are having two previously finished holes, are easily located by two cylindrical pins

These pins are projecting from the jig or fixture base which are used to engage each hole of the workpiece, as shown in Fig.

Consider, a workpiece located on pin 'P' and for accurate location there is a small clearance between pin 'P' and hole 'P'.

After correct location of pin 'P', the workpiece can rotate in either direction about that pin as shown.

Hence, due to clearance between pins and holes, centre distance between two holes and two pins does not remain fixed.

**OUR CENTERS :**

**KALYAN | DOMBIVLI | THANE | NERUL | DADAR**

**Contact - 9136008228**



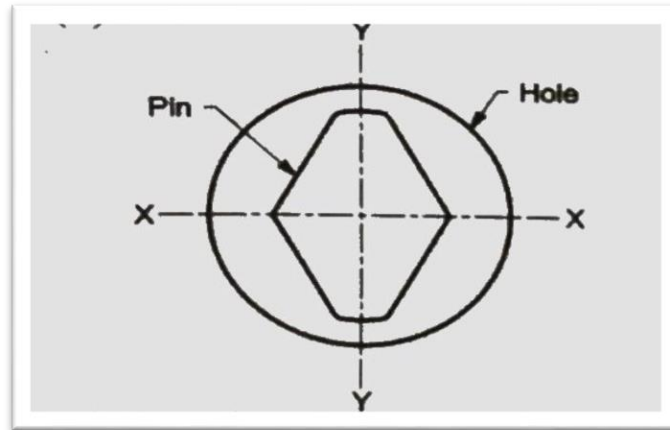

Fig

Hence, to obtain accurate location of the workpiece the relief is provided on two sides of the pin. The main purpose of relief is, to allow variation in X-X and Y-Y direction. After providing the relief, the pin looks like diamond shape hence called as diamond locators.

e) Single point cutting tool geometry asa system

[5]

Ans :

**Important Terms and Angles of Single Point Cutting Tool**

**OUR CENTERS :**

**KALYAN | DOMBIVLI | THANE | NERUL | DADAR**

**Contact - 9136008228**

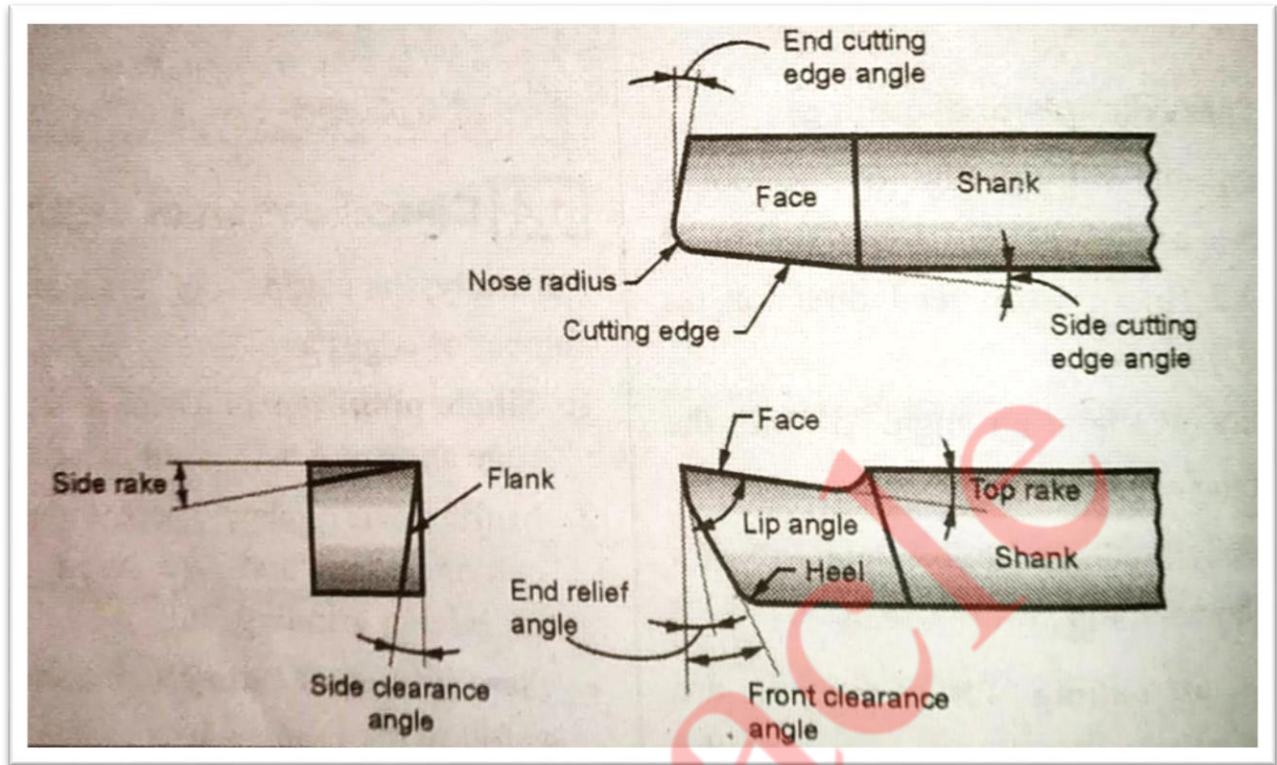

**Fig**

Fig. shows the geometry and principal angles of the single point cutting tool, which are used for designation purpose. Many times, it is also called as nomenclature of the single point cutting tool. Following are the important terms which are related to cutting tool:

**a) Shank :**

It is the main body of a solid tool, which is gripped in the tool holder.

**b) Face :**

The top surface of the tool between the shank and tool point is known as face of the tool. While cutting, the chips flow along this face only.

**c) Point :**

It is the cutting part of the tool. Sometimes, it is also called as nose. It is the wedge shaped portion where the face and flank of the tool meet.

**d) Flank**

It is the portion of the tool which faces the work. Also, it is the surface adjacent to and below the cutting edge.

**OUR CENTERS :**

**KALYAN | DOMBIVLI | THANE | NERUL | DADAR**

**Contact - 9136008228**

**e) Base :**

It is the surface of the tool on which it is oped in a tool holder or directly clamped in a tool post.

**f) Heel :**

The curved portion at the bottom of the tool where base and flank meat is called as heel.

**g) Nose radius:**

If a cutting tip (nose) of a single point tool carries a sharp cutting point, then it will produce a mark on the machined surface.

Hence, to prevent this effect, a nose is provided with radius, called as nose radius.

Generally, nose radius is between 0.4 mm to 0.16 mm depending on factors like depth of cut, feed, type of cutting, tool type, etc.

**h) Rake angle:**

Rake angle is the angle between the tool face and a plane parallel to its base. It is also termed as positive rake angle.

If the inclination is towards the shank, then it is called as top rake or back rake angle.

When inclination is measured towards the side of the tool, then it is known as side rake angle.

Generally, value of rake angle is low because low rake angle increases the strength of the tool.

When tool face is so ground that it slopes upwards from the point then it is called as negative rake angle.

**i) Clearance angle:**

It is the angle between front or side tool surfaces, which are adjacent and below the cutting edge when the tool is in horizontal position.

When the front surface of the tool i.e. just below the point is considered, then the angle is called as front clearance angle.

When the surface below the side cutting edge is considered, then the angle is called as side clearance angle.

**j) Lip angle:**

It is the angle between the tool face and flank of the tool.

Strength of the cutting edge or point of the tool directly changes as per lip angle. If the lip angle is larger, then higher will be the strength of the tool and vice versa.

**OUR CENTERS :**

**KALYAN | DOMBIVLI | THANE | NERUL | DADAR**

**Contact - 9136008228**

Lip angle varies inversely with the rake angle. Hence, for machining of hard metals rake angle is reduced and lip angle is increased.

**k) Relief angle:**

It is the angle between the tool flank and a normal line drawn from the cutting point to the tool base.

**l) Cutting angle :**

It is angle between the tool face and a line through the point. The line is tangent to the machined surface of the work.

Pinnacle

**OUR CENTERS :**

**KALYAN | DOMBIVLI | THANE | NERUL | DADAR**

**Contact - 9136008228**